

MUNDIPERFIL®

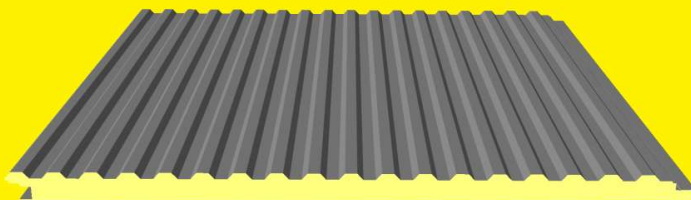

SOLUÇÕES PARA COBERTURAS E FACHADAS

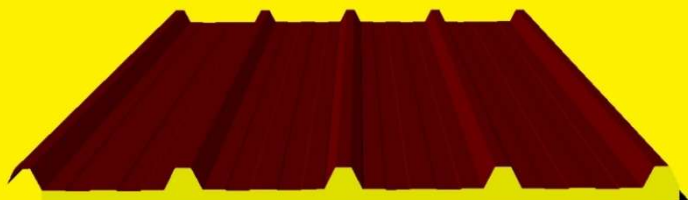

WWW.MUNDIPERFIL.COM



PAINEL COBERTURA EM POLIURETANO (PUR ou PIR)

PAINEL **MUNDITELHA**® (Com chapa de Aço ou Alumínio lacada)

(MARCA E DESENHO REGISTRADOS NO INPI)

ESPESSURAS MÉDIAS: 40 - 60 mm

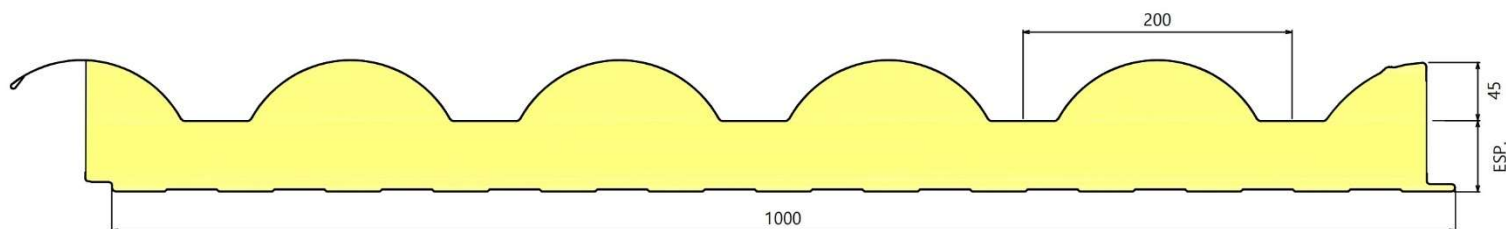
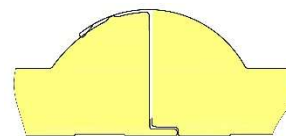

PAINEL **MUNDIMARSELHA**® (Com chapa de Aço ou Alumínio lacada)

(MARCA E DESENHO REGISTRADOS NO INPI)

ESPESSURA MÉDIA: 50 mm

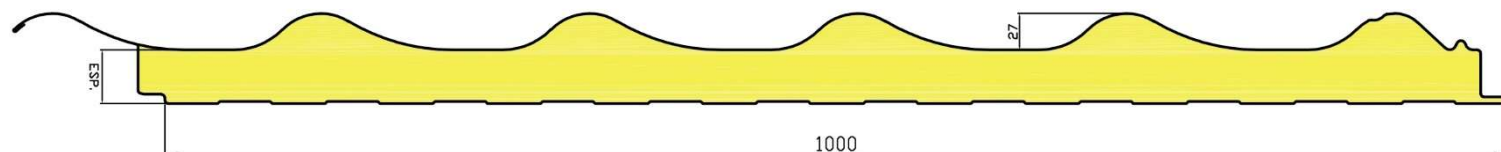
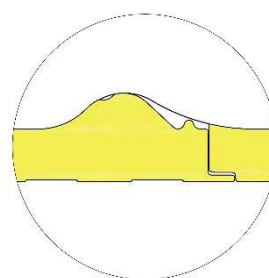

COMPRIMENTOS PRODUZIDOS:

2.100mm	2.450mm	2.800mm	3.150mm	3.500mm	3.850mm	4.200mm	4.550mm	4.900mm	5.250mm
5.600mm	5.950mm	6.300mm	6.650mm	7.000mm	7.350mm	7.700mm	8.050mm	8.400mm	8.750mm
9.100mm	9.450mm	9.800mm	10.150mm	10.500mm	10.850mm	11.200mm	11.550mm	11.900mm	12.250mm
12.600mm	12.950mm	13.300mm	13.650mm	14.000mm	14.350mm	14.700mm	15.050mm	15.400mm	15.750mm

Outros comprimentos sob consulta.

PAINEL POLIURETANO COBERTURA 5 ONDAS

REF: "MC 1000/5"

ESPESSURAS: 30 - 40 - 50 - 60 - 80 - 100 mm

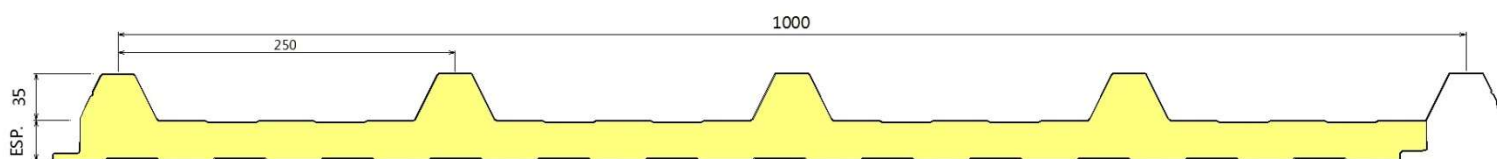
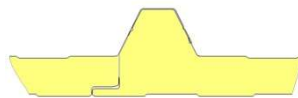
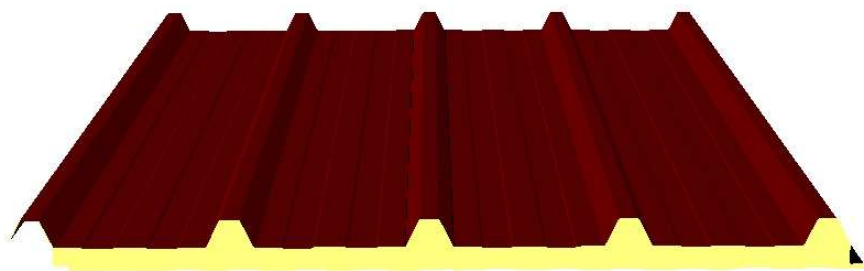

PAINEL POLIURETANO COBERTURA 4 ONDAS

REF: "MC 1000/4"

ESPESSURAS: 30 - 40 - 50 - 60 - 80 - 100 mm

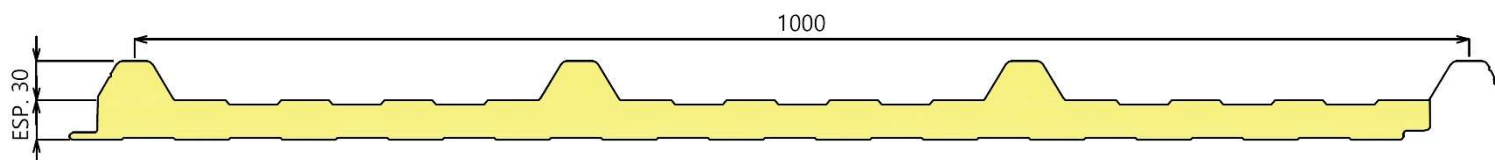
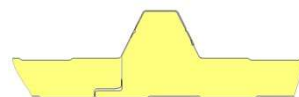

PAINEL POLIURETANO COBERTURA FIXAÇÃO OCULTA 4 ONDAS

REF: "MC 1000/TJ"

ESPESSURAS: 30 - 40 - 50 - 60 - 100 mm

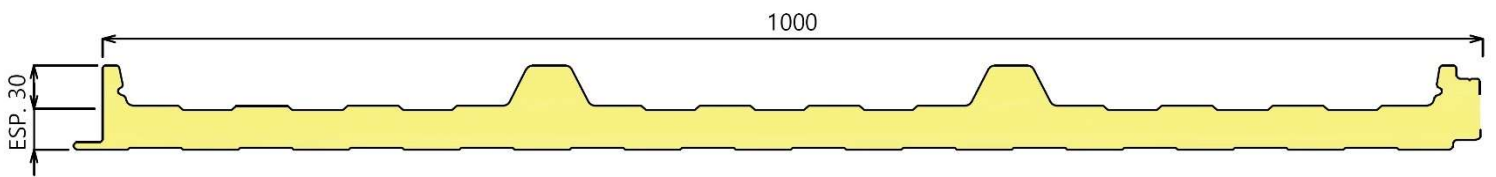
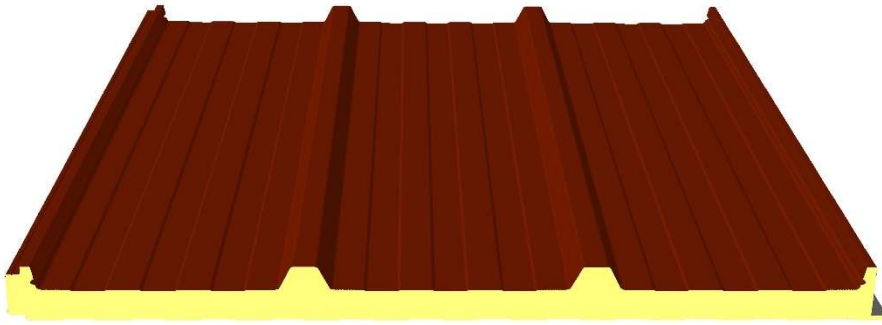

PAINEL MUNDIAGRO® (CHAPA DE FIBRA NO INTERIOR)

5 ONDAS

ESPESSURAS: 30 - 40 - 50 - 60 - 80 - 100 mm

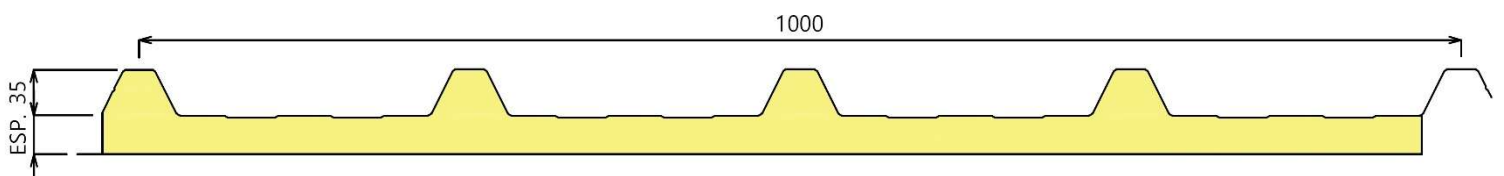
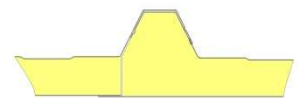
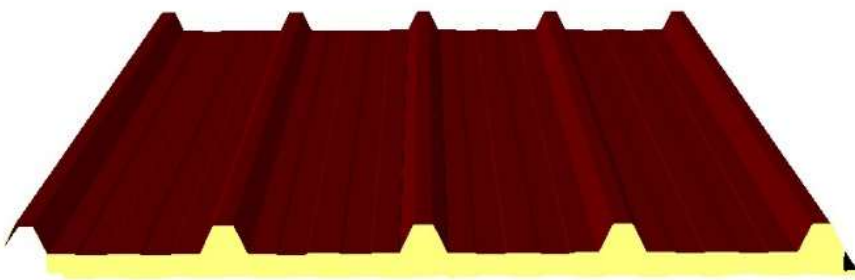

PAINEL FACHADA EM POLIURETANO (PUR ou PIR)

PAINEL POLIURETANO FACHADA FIXAÇÃO OCULTA JUNTA FECHADA/ABERTA TIPO A
REF: "MF 1000 JF/A" ou "MF 1000 JA/A"

ESPESSURAS: 40 - 50 - 60 mm

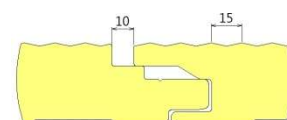
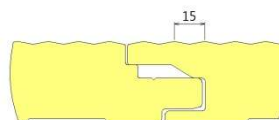
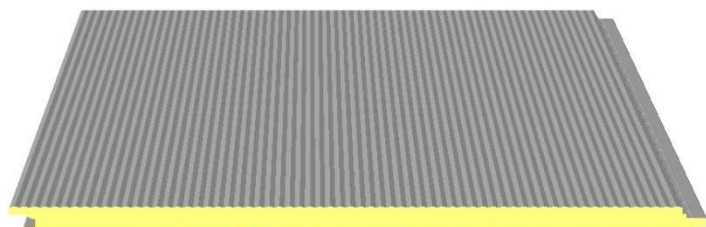

PAINEL POLIURETANO FACHADA FIXAÇÃO OCULTA JUNTA FECHADA/ABERTA TIPO B
REF: "MF 1000 JF/B" ou "MF 1000 JA/B"

ESPESSURAS: 40 - 50 - 60 mm

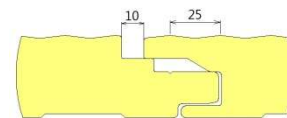
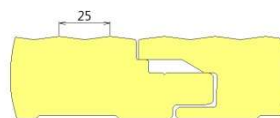
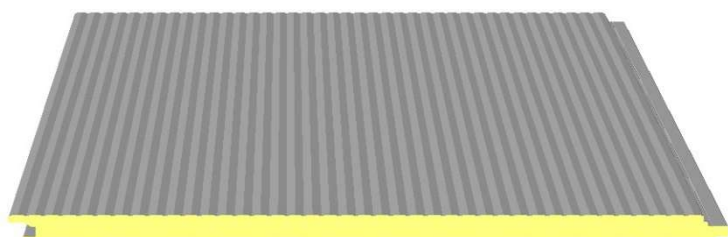

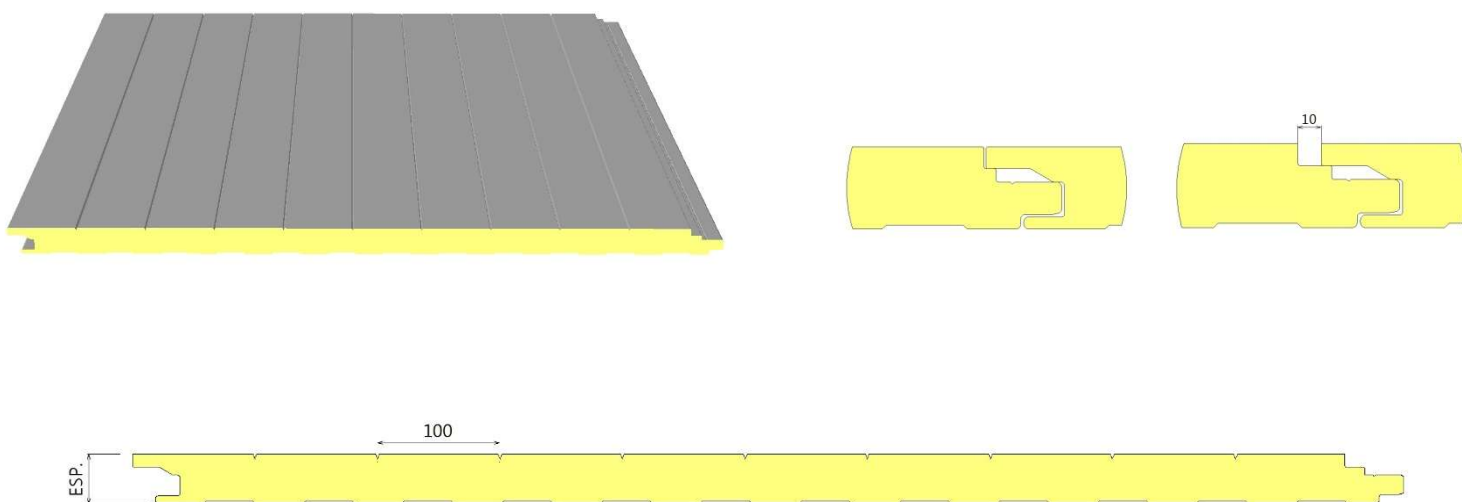
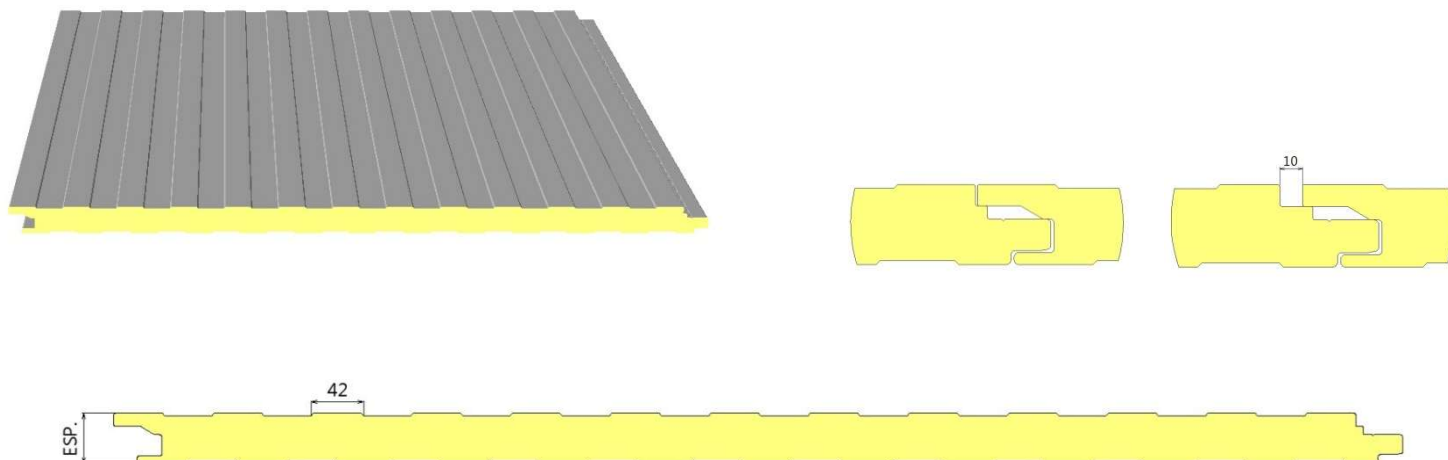

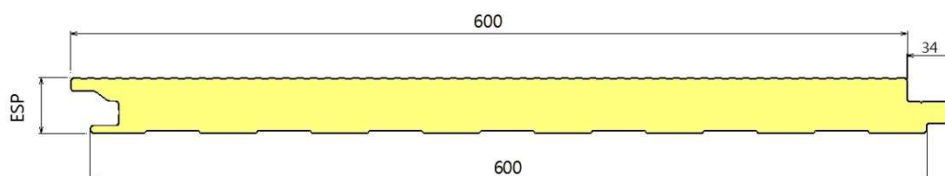
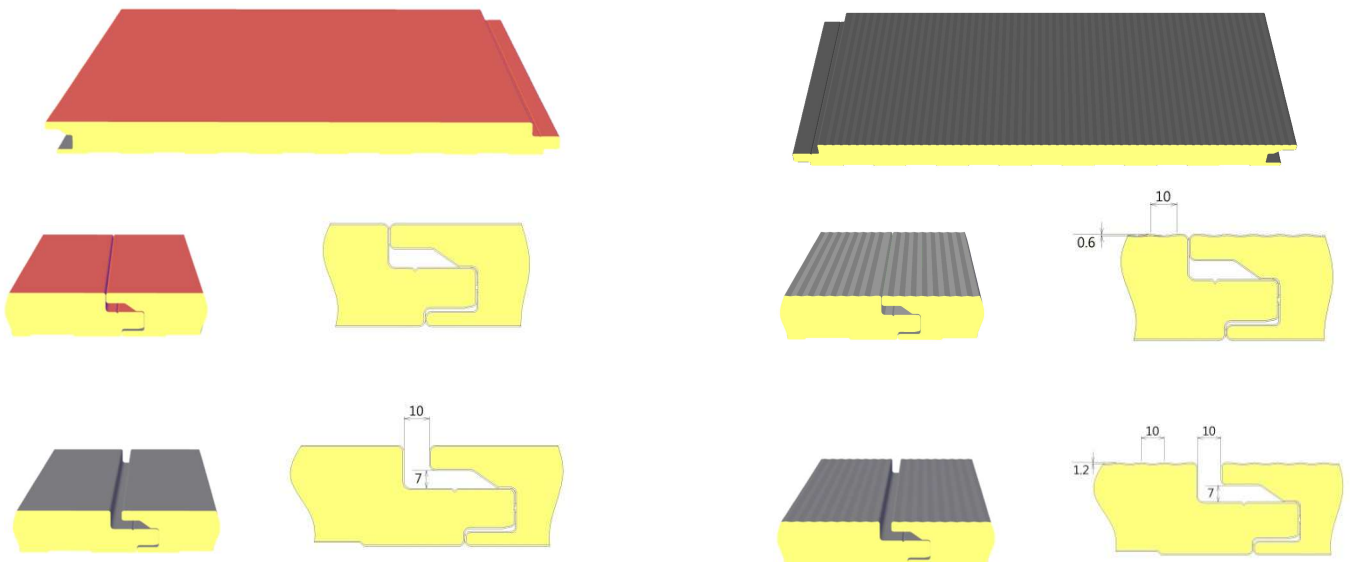
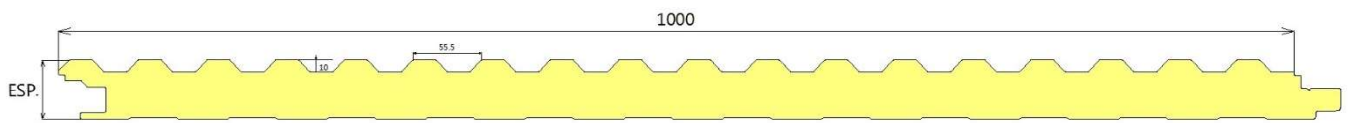
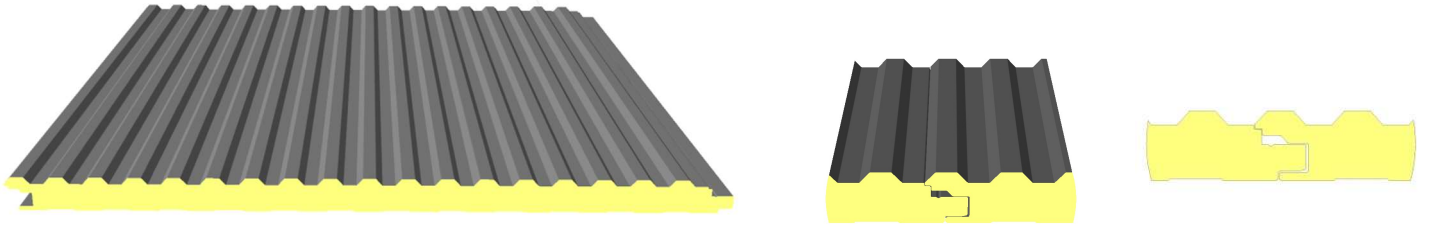

PAINEL DIVISÓRIA / TETO FALSO EM POLIURETANO (PUR ou PIR)

PAINEL POLIURETANO DIVISÓRIA / TETO FALSO TIPO A
REF: "MR 1000 A"

ESPESSURAS: 30 - 40 - 50 - 60 - 80 - 100 mm

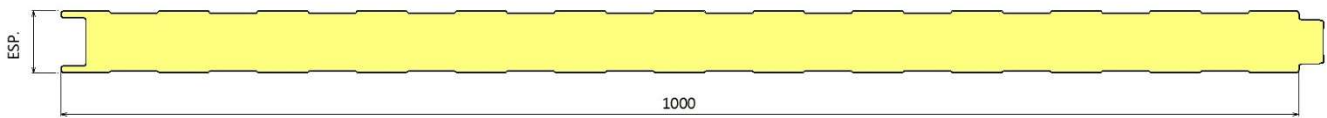
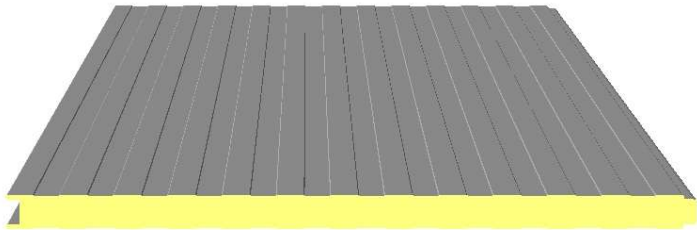

PAINEL POLIURETANO DIVISÓRIA / TETO FALSO TIPO B
REF: "MR 1000 B"

ESPESSURAS: 30 - 40 - 50 - 60 - 80 - 100 mm

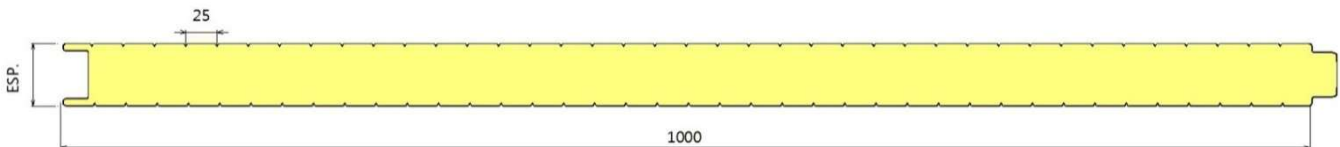
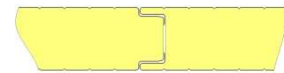
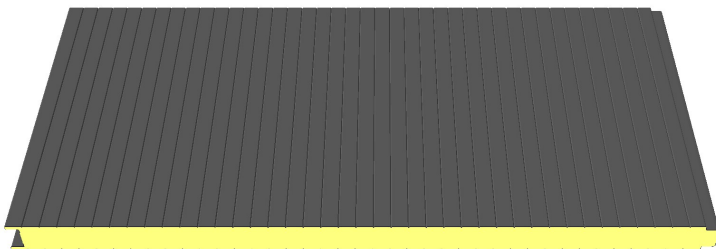

PAINEL POLIURETANO DIVISÓRIA / TETO FALSO TIPO C (liso 1 ou 2 faces)
REF: "MR 1000 C1" ou "MR 1000 C2"

ESPESSURAS: 30 - 40 - 50 - 60 - 80 - 100 mm

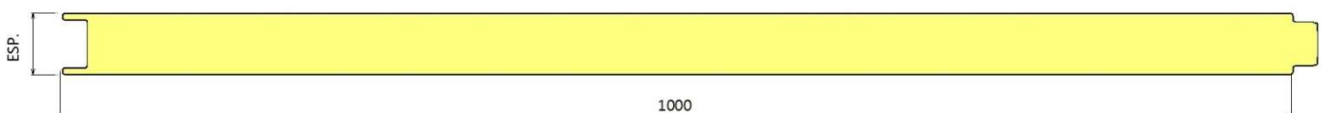

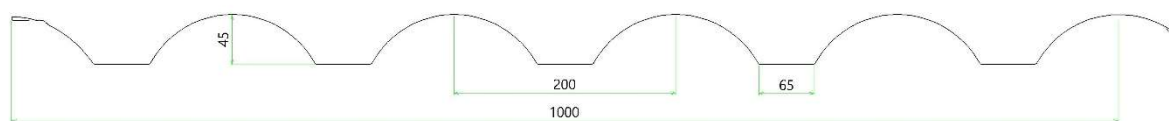
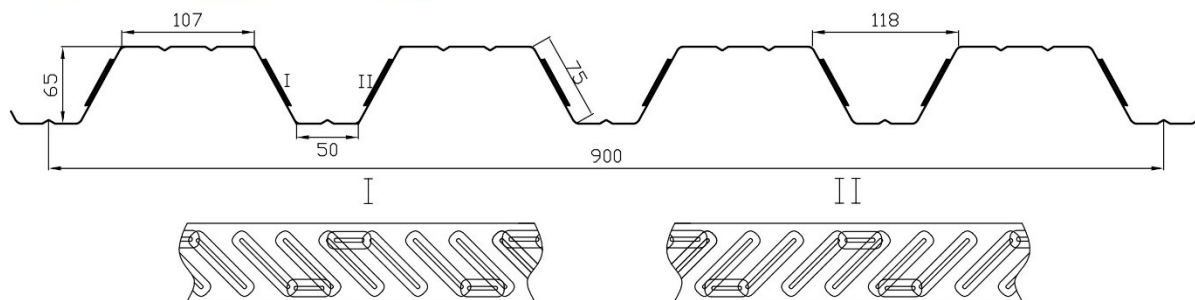
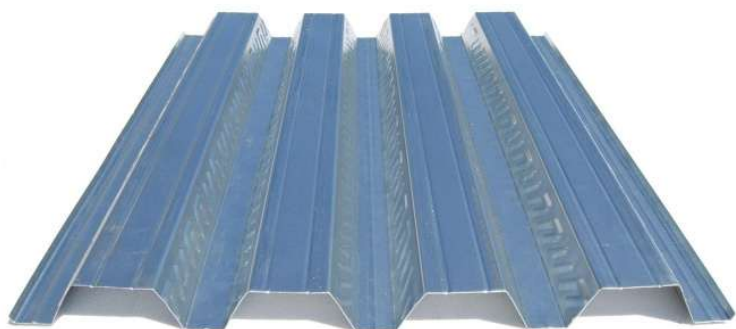

MP-40/1000

ESPESSURAS: 0,4 - 0,5 - 0,6 mm

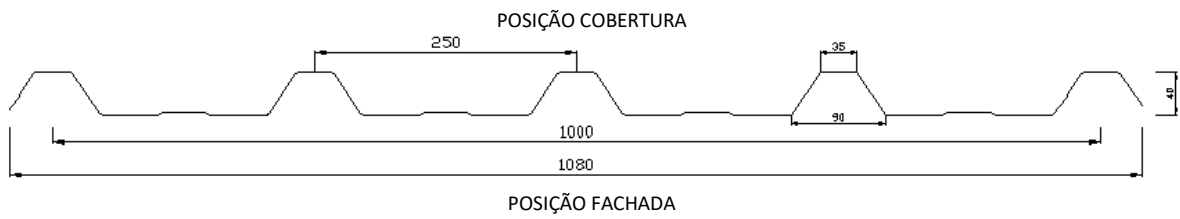
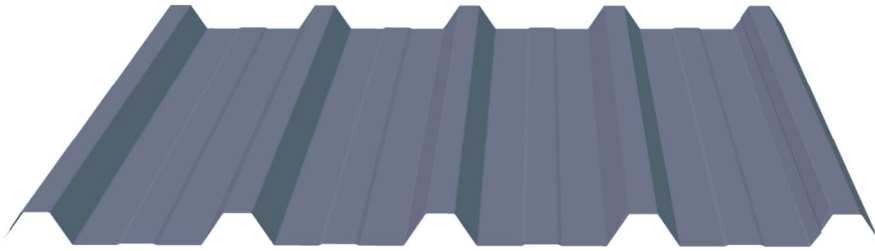

MP-30/1100/1

ESPESSURAS: 0,4 - 0,5 - 0,6 mm

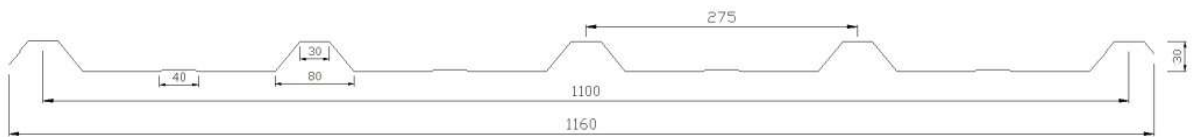
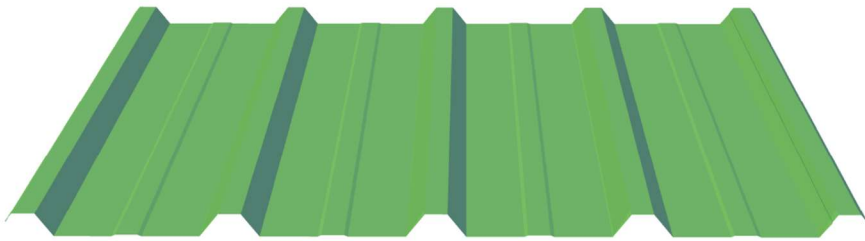

MP-30/1100/2

ESPESSURAS: 0,4 - 0,5 - 0,6 mm

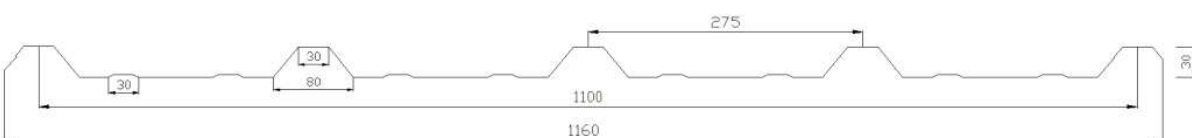
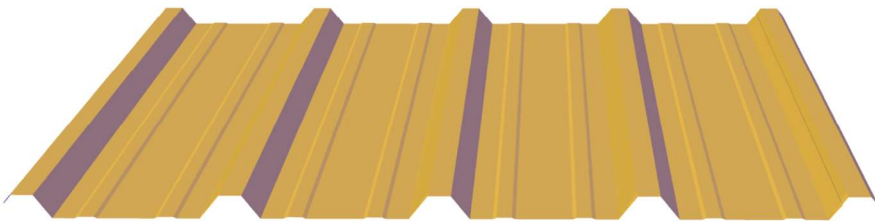

MP-30/1100/3

ESPESSURAS: 0,4 - 0,5 - 0,6 mm

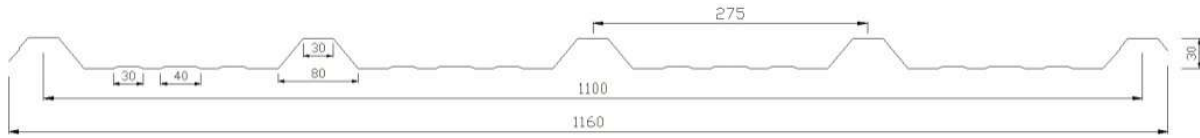
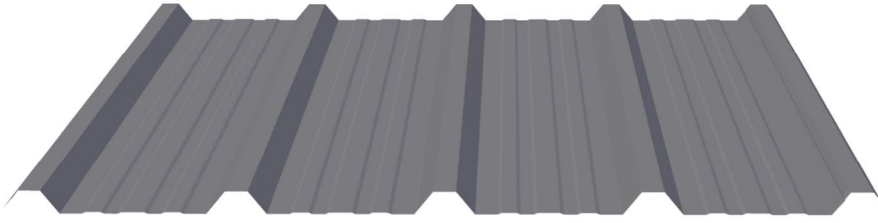

MP-28/1050

ESPESSURAS: 0,4 - 0,5 - 0,6 mm

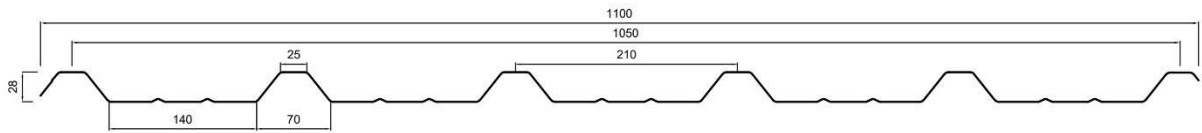

MP-25/1000

ESPESSURAS: 0,4 - 0,5 - 0,6 mm

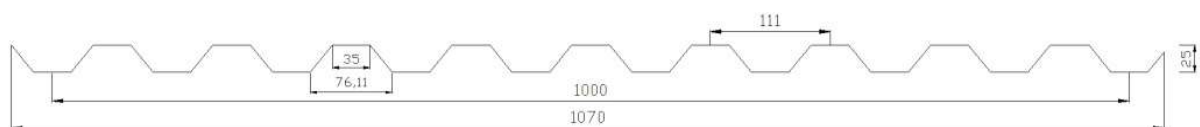
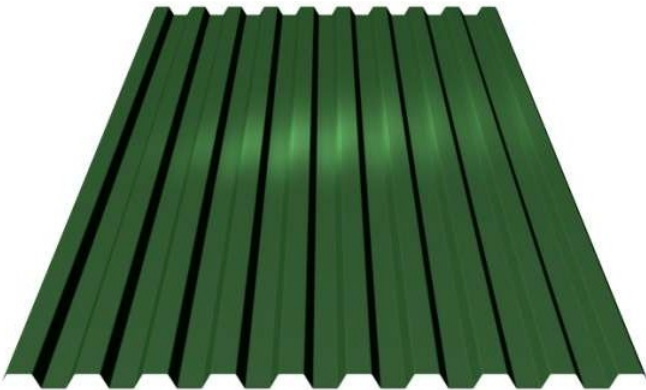

MP-18/1064

ESPESSURAS: 0,4 - 0,5 - 0,6 mm

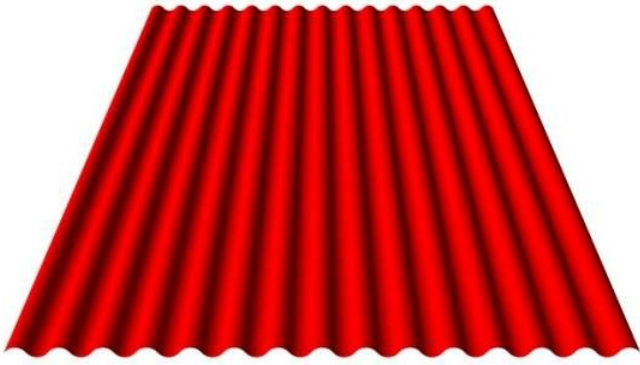

CE

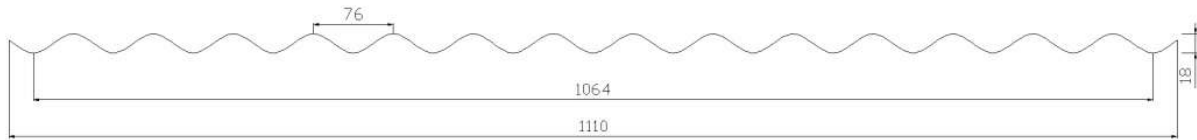

MP-12/1100

ESPESSURAS: 0,4 - 0,5 - 0,6 mm

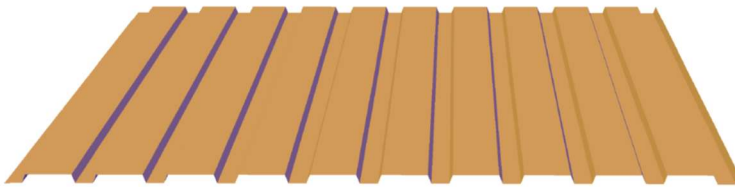

CE

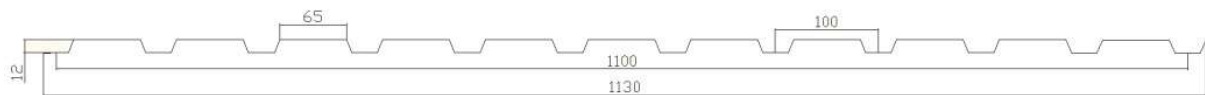

MP-10/1040

ESPESSURAS: 0,4 - 0,5 - 0,6 mm



CE

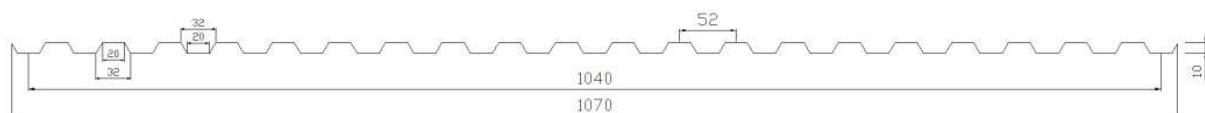

REMATES MUNDITELHA® / MUNDIMARSELHA®
 (FAZEMOS QUALQUER REMATE MEDIANTE DESENHO DO CLIENTE)

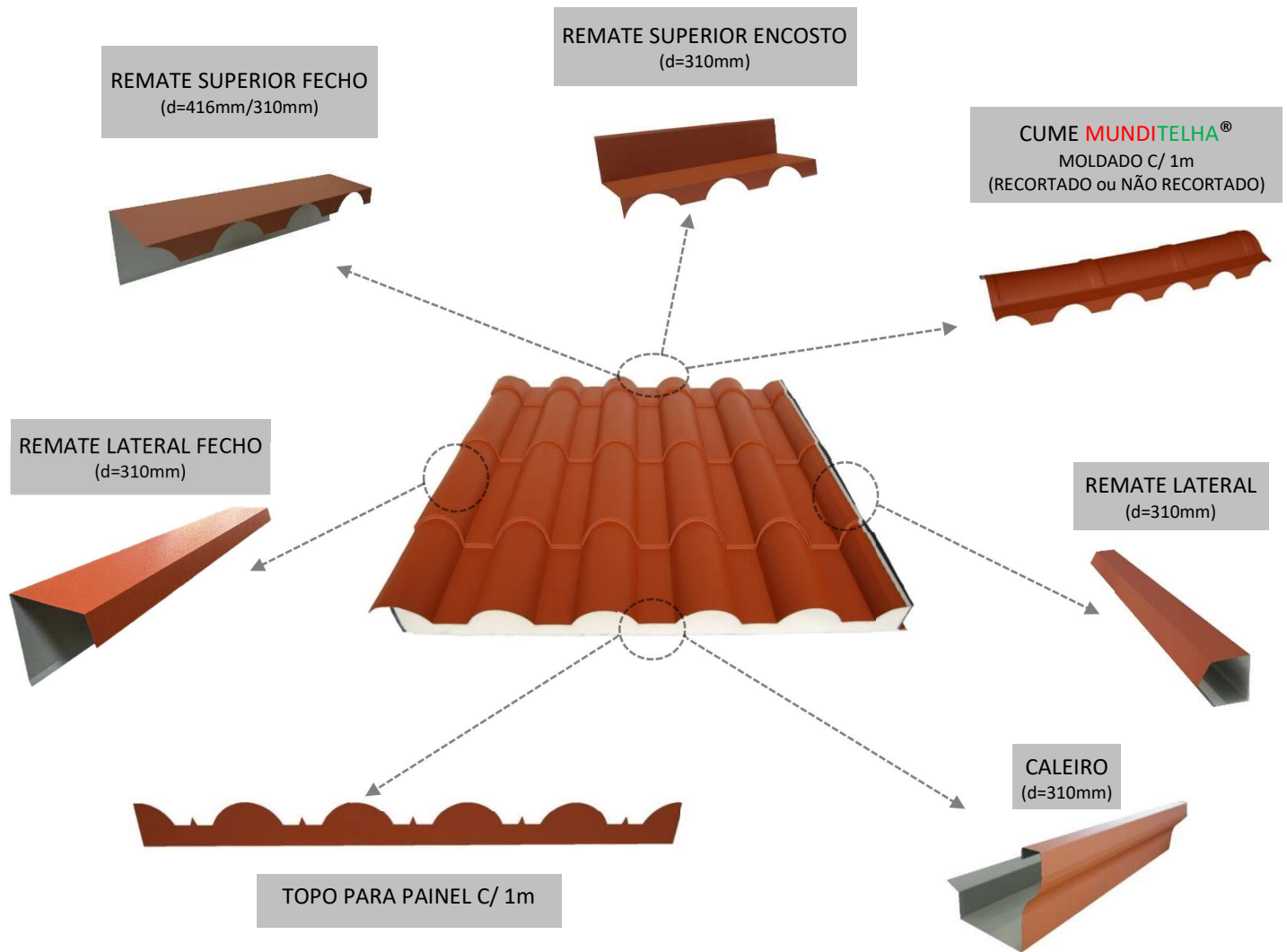

OUTROS REMATES
 (FAZEMOS QUALQUER REMATE MEDIANTE DESENHO DO CLIENTE)



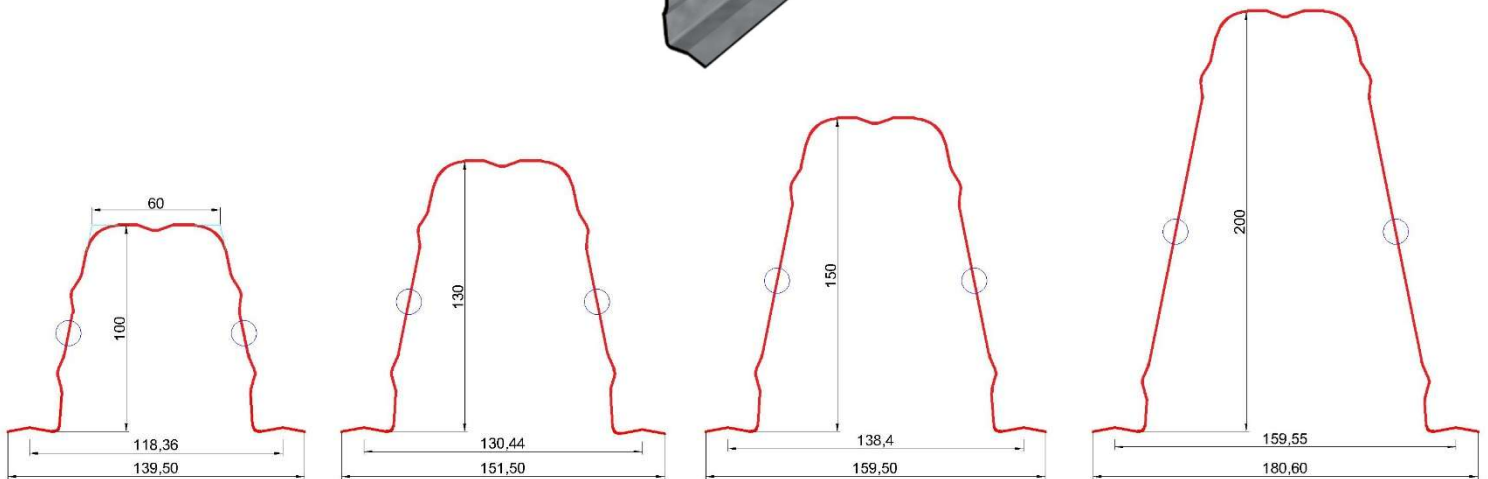
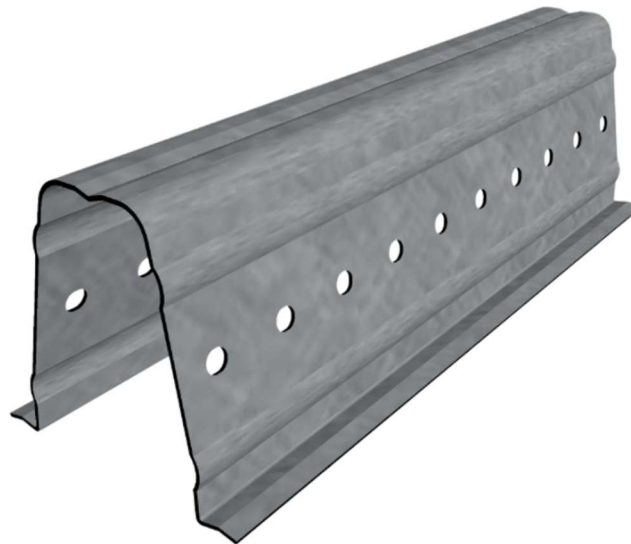

Referência	Espessura (mm)	Área (cm ²)	Massa (kg/m)	Perímetro (mm)	Área Pintura (m ² /m)	Largura (b) (mm)	Altura (h) (mm)	x _{cg} (mm)	y _{cg} (mm)	I _x (cm ⁴)	I _y (cm ⁴)	I _{xy} (cm ⁴)	i _x (cm)	i _y (cm)
MO® 100x1,50	1,50	4,60	3,61	616	0,6164528	139,5	100,0	69,8	52,3	61,64	77,62	-0,000025	3,66	4,11
MO® 100x2,00	2,00	6,14	4,82	618	0,6176283	139,7	100,0	69,9	52,6	82,21	104,23	0,006581	3,66	4,12
MO® 100x2,50	2,50	7,67	6,02	619	0,6187788	139,9	100,0	69,9	52,9	102,80	131,21	0,011114	3,66	4,14
MO® 130x1,50	1,50	5,52	4,33	739	0,7387886	151,5	130,0	75,8	67,4	117,88	109,74	0,005638	4,62	4,46
MO® 130x2,00	2,00	7,36	5,78	740	0,7399716	151,7	130,0	75,9	67,8	157,20	147,32	-0,004593	4,62	4,47
MO® 130x2,50	2,50	9,20	7,22	741	0,7411348	151,9	130,0	75,9	68,1	196,62	185,41	-0,003331	4,62	4,49
MO® 150x1,50	1,50	6,13	4,81	820	0,8204151	159,5	150,0	79,8	77,5	168,91	135,02	0,008692	5,25	4,69
MO® 150x2,00	2,00	8,18	6,42	822	0,8215975	159,7	150,0	79,9	77,8	225,26	181,21	0,017561	5,25	4,71
MO® 150x2,50	2,50	10,22	8,02	823	0,8227541	159,9	150,0	79,9	78,2	281,71	228,04	-0,002518	5,25	4,72
MO® 200x1,50	1,50	7,66	6,01	1025	1,0246856	180,6	200,0	90,3	102,6	353,01	214,20	-0,001419	6,79	5,29
MO® 200x2,00	2,00	10,22	8,02	1026	1,0258677	180,8	200,0	90,4	102,9	470,87	287,34	-0,010882	6,79	5,30
MO® 200x2,50	2,50	12,77	10,03	1027	1,0270161	181,0	200,0	90,5	103,3	588,74	361,33	-0,011070	6,79	5,32

Materiais:			
Classe do Aço	S280GD	Tensão	Tensão
		Cedência (Mpa)	Rotura (Mpa)
		280	360
Pré-Galvanizado	Z275	Massa	Espessura
		Rev.Sup. (g/m ²)	Rev.Sup. (u/face)
		275	20

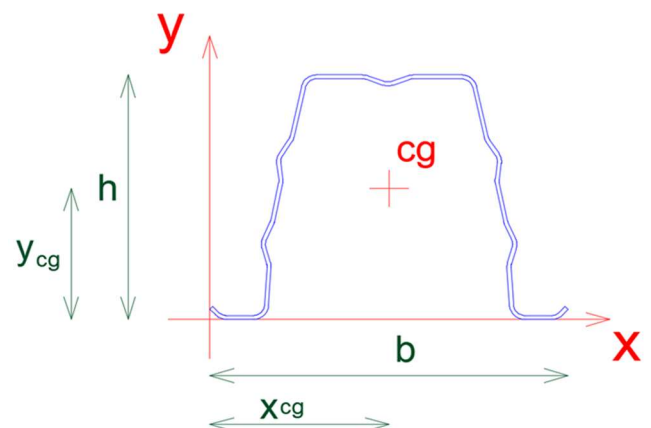

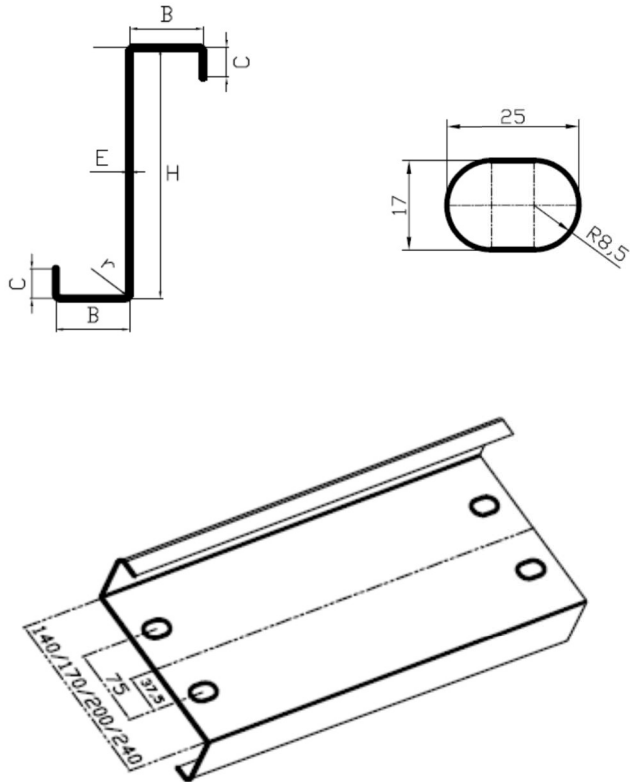

Referência	H	B	E	C	r	DII	IXX(cm ⁴)	WXX(cm ³)	IXX(cm)	IYY(cm ⁴)	WYY(cm ³)	IYY(cm)	Kg/ML
Z 140-1,5	140	50	1,5	20	3	280	145,27	22,12	5,67	67,33	7,45	3,48	3,28
Z 140-2,0	140	50	2,0	20	3	280	189,94	26,80	5,63	71,05	9,65	3,44	4,37
Z 140-2,5	140	50	2,5	20	3	280	233,46	32,95	5,60	86,31	11,77	3,41	5,46
Z 170-1,5	170	50	1,5	20	5	310	257,32	29,14	7,09	58,45	7,48	3,24	3,63
Z 170-2,0	170	50	2,0	20	5	310	339,85	37,34	7,07	71,07	9,64	3,23	4,84
Z 170-2,5	170	50	2,5	20	5	310	418,61	46,01	7,05	86,33	11,74	3,20	6,05
Z 200-1,5	200	60	1,5	20	5	360	348,25	34,25	7,79	59,63	7,51	3,17	4,22
Z 200-2,0	200	60	2,0	20	5	360	434,78	43,02	7,77	71,08	9,63	3,14	5,62
Z 200-2,5	200	60	2,5	20	5	360	535,97	53,04	7,75	86,34	11,73	3,11	7,02
Z 240-1,5	240	60	1,5	20	5	400	417,90	41,10	9,34	71,55	9,01	3,80	4,68
Z 240-2,0	240	60	2,0	20	5	400	521,73	51,62	9,32	85,29	11,55	3,76	6,24
Z 240-2,5	240	60	2,5	20	5	400	643,16	63,64	9,30	103,60	14,07	3,73	7,8

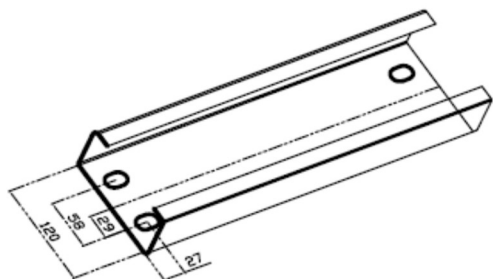
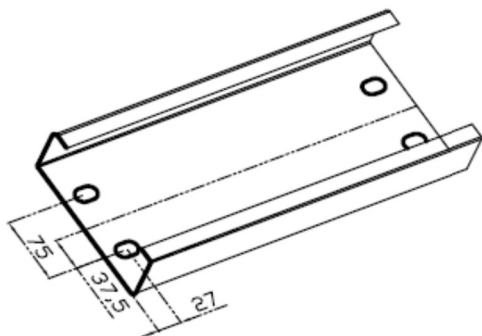
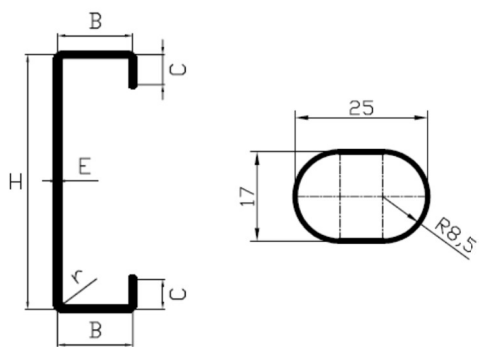

Referência	H	B	E	C	r	DII	IXX(cm ⁴)	WXX(cm ³)	IXX(cm)	IYY(cm ⁴)	WYY(cm ³)	IYY(cm)	Kg/ML
C 120-1,5	120	50	1,5	20	2,5	260	82,07	13,24	4,75	12,78	3,87	1,85	3,05
C 120-2,0	120	50	2,0	20	2,5	260	105,23	17,54	4,72	15,85	4,64	1,83	4,06
C 120-2,5	120	50	2,5	20	3	260	128,01	21,34	4,69	18,96	5,55	1,81	5,07
C 140-1,5	140	50	1,5	20	5	280	156,45	20,85	5,64	34,22	7,12	2,61	3,28
C 140-2,0	140	50	2,0	20	5	280	189,37	27,05	5,62	40,20	8,63	2,59	4,37
C 140-2,5	140	50	2,5	20	5	280	232,76	33,25	5,60	48,93	10,51	2,57	5,46
C 170-1,5	170	50	1,5	20	5	310	274,21	29,76	7,09	35,26	6,55	2,57	3,63
C 170-2,0	170	50	2,0	20	5	310	339,10	37,68	7,06	43,75	8,80	2,54	4,84
C 170-2,5	170	50	2,5	20	5	310	417,69	46,41	7,04	53,27	10,83	2,51	6,05
C 200-1,5	200	60	1,5	20	5	360	351,23	34,67	7,80	36,21	7,32	2,54	4,22
C 200-2,0	200	60	2,0	20	5	360	433,94	33,39	7,77	45,23	8,99	2,51	5,62
C 200-2,5	200	60	2,5	20	5	360	534,95	53,50	7,74	55,07	10,95	2,48	7,02

OMEGA 80

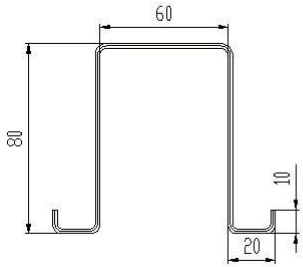

OMEGA 100

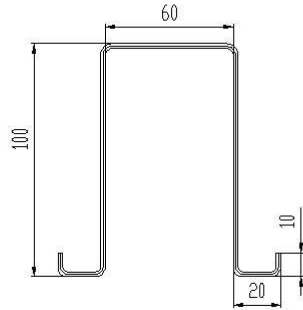

OMEGA 130

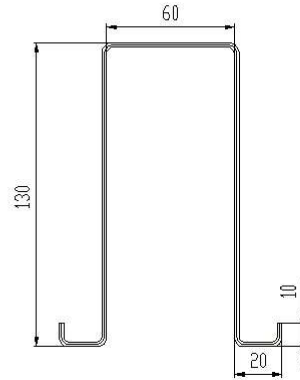

OMEGA 150

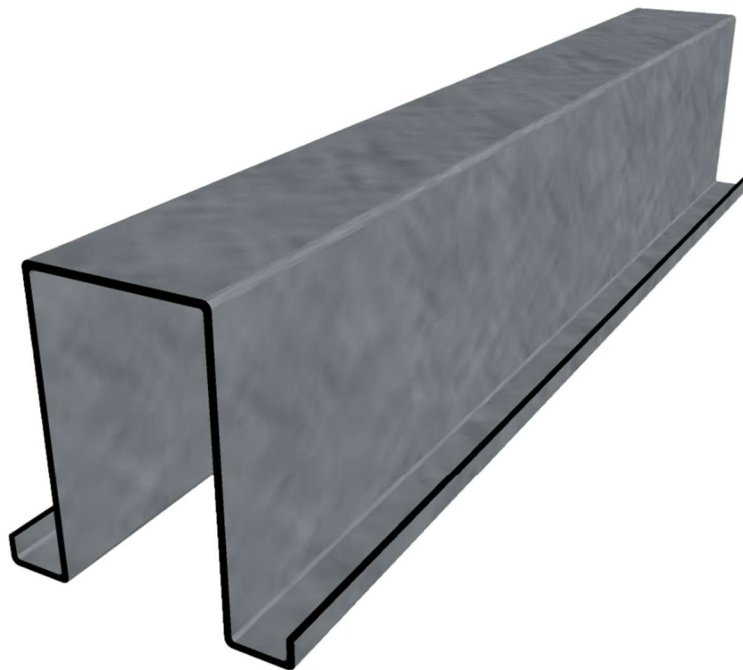
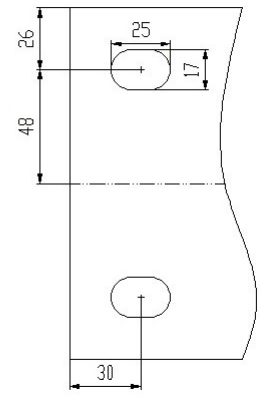
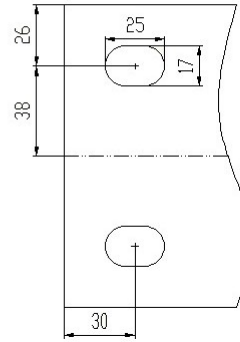
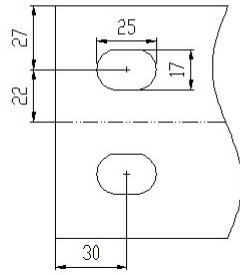
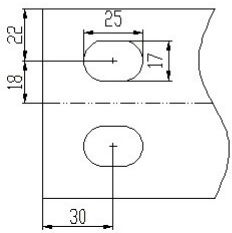
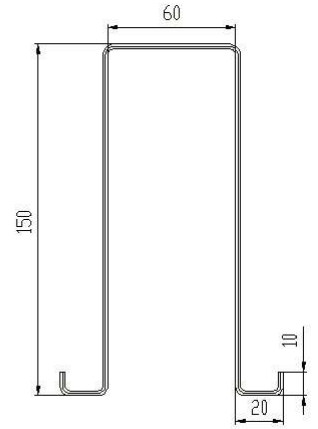



CORES COM ACABAMENTO POLIÉSTER RUGOSO



Barro RAL 8023 rug.



Barro RAL 8004 rug.



Castanho RAL 8017 rug.

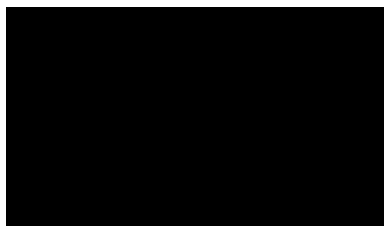

Preto RAL 9005 rug.



Cinza RAL 7022 rug.



Cinza RAL 7016 rug.



Imitação Telha Velha Escura



Imitação Telha Velha Clara

CORES COM ACABAMENTO IMITAÇÃO MADEIRA



Madeira intermédia



Madeira Clara



Madeira NVI

ACABAMENTOS ESPECIAIS PARA FACHADAS EXTERIORES (Painel Fachada Fixação Oculta)



Madeira NVI



Imitação Corten



Imitação Granito

CORES COM ACABAMENTO LISO (Standard)

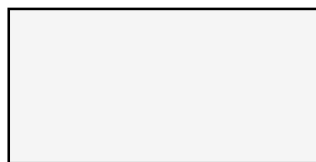

Branco RAL 9010



Telha RAL 3009



Metal. RAL 9006



Creme RAL 1015



Verde RAL 6005



Cinza RAL 7016



Azul RAL 5010



Metal RAL 9007



Cinza RAL 7022



Gris Pérola RAL 7038



Cinza RAL 7012

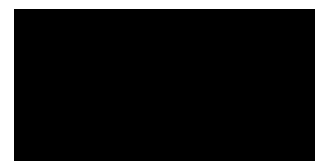

Preto RAL 9005



Telha RAL 8004

MUNDIPERFIL DISTRIBUIÇÃO, LDA

Rua da Ponte Nova, 180
4755-529 Várzea, Barcelos, Portugal
Tel: +351 253 834 545
Fax: +351 253 834 268

mundiperfil@mundiperfil.pt
www.mundiperfil.pt